

Code P0775BS Description R45L C+C CFZ ANONIMO 100/1000 PZ

Base

Range CONTENTORI E COP. ALLUMI Stock Category CO
Lid Not expected

General characteristics

Ean Code 8011851201005 External Surface Nudo/Plain
Internal Surface Nudo/Plain Package Wrinkle

General dimensions

	940		202 X 137
	186 X 121		161 X 96
	50	Net Weight (gr)	8,479

Patch features

Nr. Pcs per Stack 100 Nr. Stacks per box 10
Nr. Pcs per Box 1.000 Carton Volume (cm³) 0,106

Pallet features

Pallet Height (mm) 2.380 Nr. Boxes per layer 4
Nr. Layers per box 5 Total Weight - Pallet (kg) 185,78
Nr. Pcs per Pallet 20.000 Pallet EUROPALLET IN LEGNO

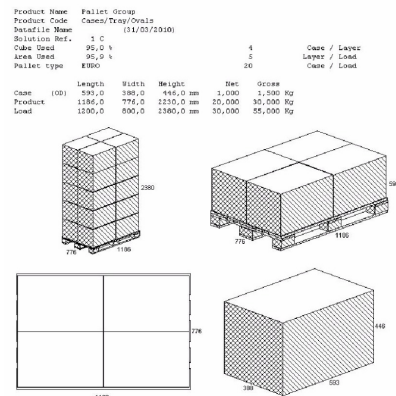

The products are suitable for contact with food in accordance with the prescriptions and limits of current legislation Material Aluminium Alloy.All products conform to Regulations (EC) N°1935/2004 and N°882/2004 of the European Parliament, to Commission Regulation (EC) N°2023/2006.
All products in according to technical norms: UNI EN 602, UNI EN 546-1, UNI EN 546-2, UNI EN 546-3, UNI EN 546-4, EN ISO 6886.

Contital S.r.l

Società soggetta all'attività di direzione e coordinamento della LAMINAZIONE SOTTILE S.p.a.

Sede Amm.va e Stab: Via Appia Km.192,358 Pignataro Maggiore (CE) ITALY - Tel +39 0823.873111 - Fax +39 0823.654666 - email: onfo@contital.com

Sede legale: Via Cannola al Trivio ,28 - 80141 NAPOLI ITALY - Codice Fiscale, Partita IVA e Numero R.I Napoli 06237980633 Codice identificativo CEE IT 06237980633 - R.E.A Napoli n.480674 - Trib di Napoli n. 558/91 - Capitale Sociale : 260,000 int. vers.

05 September 2019

Pag 1 di 1